

FLEET ENGINEERS INCORPORATED



PATENT #6,471,228

Installation Sheet #INS-01015
For Mounting Quarter and Tandem Fenders

NOTE: These instructions for installation are intended to be a general guide to help the installer. Because of the large number of possible mounting configurations, the installer is responsible for the installation design. Any modifications to the product are at the discretion, responsibility and risk of the installer.

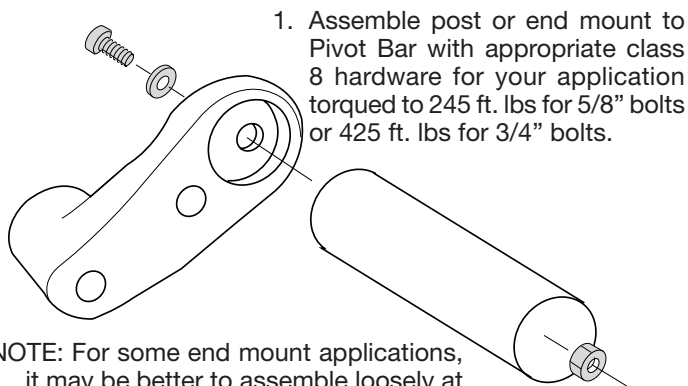

1. Assemble post or end mount to Pivot Bar with appropriate class 8 hardware for your application torqued to 245 ft. lbs for 5/8" bolts or 425 ft. lbs for 3/4" bolts.

NOTE: For some end mount applications, it may be better to assemble loosely at first and then torque at final assembly.

2. Select a hole in the frame for mounting. Position Pivot Bar to hole and attach loosely with appropriate hardware

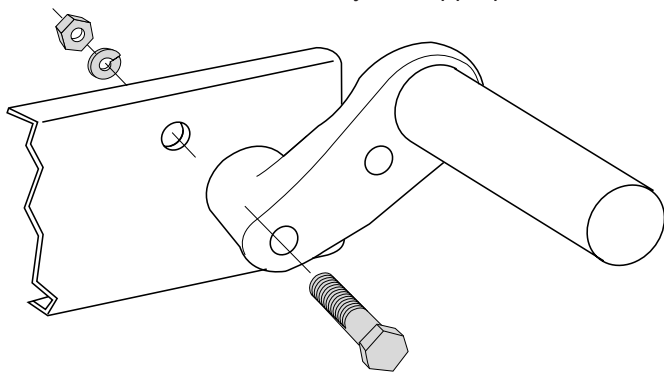

3. Rotate Pivot Bar to the desired position for mounting the fender then tighten the Pivot Bar to the frame mounting bolt and torque to 425 ft. lbs. minimum.

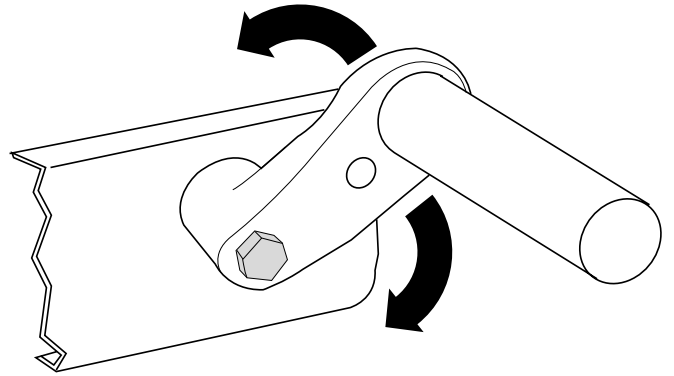

4. Thread jamming set screw into hole. Adjust it to contact truck frame and tighten to 13-15 ft. lbs. (recommended) or until a slight deflection of the Pivot Bar is seen).

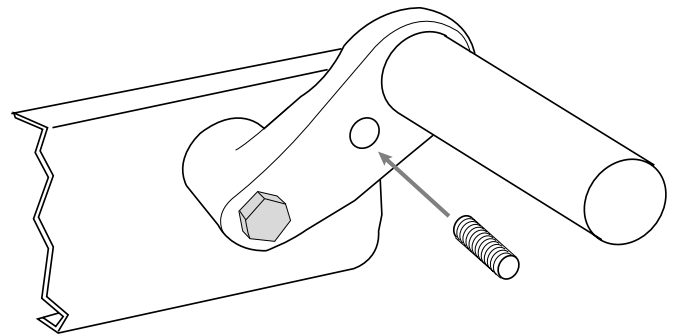

5. Tighten nut or bolt to appropriate torque (245 ft. lbs for 5/8" bolts or 425 ft. lbs for 3/4" bolts) on end or post mount if left loose (from step 1). Attach fender on post or end mount in accordance to the manufacturers instructions.

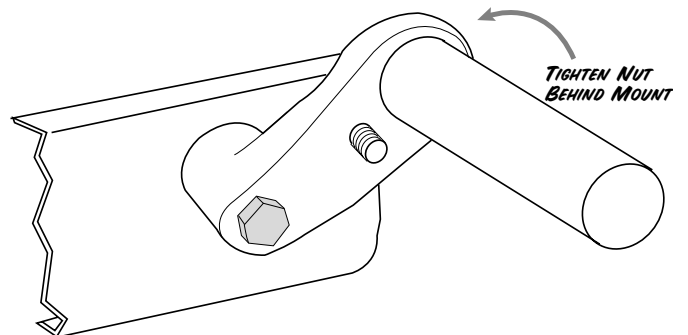

FRONT VIEW

BACK VIEW

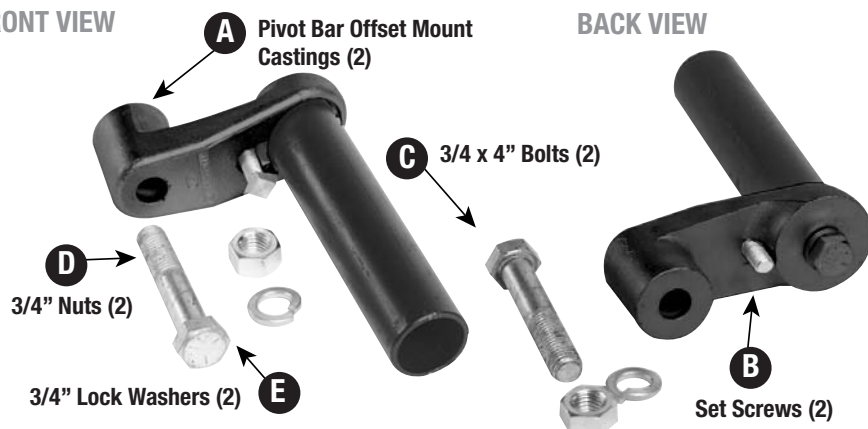

Each Standard Pivot Bar Set Includes

- A) Two Pivot Bar offset mount castings
- B) Two Set Screws
- C) Two 3/4 x 4" Bolts
- D) Two 3/4" Nuts
- E) Two 3/4" Lock Washers

Sets available with or without mounts
Fenders not included