

# FLEET ENGINEERS INCORPORATED

## Spray Master® Fender Installation Instructions

Installation Sheet #INS-03030

Patent Pending

**NOTE:** These instructions for installing Spray Master fenders are intended to be a general guide to help the installer. Because of the large number of possible mounting configurations, the installer is responsible for the installation design and for providing adequate clearance around the tire carrier (i.e. tire clearance, trailer clearance, etc.)

This product may not fit all truck models or types of suspensions. Check truck or trailer manufacturer for suspension travel specifications. Modifications to the brackets and/or the fenders may be required. Any modifications are at the discretion, responsibility and risk of the installer.

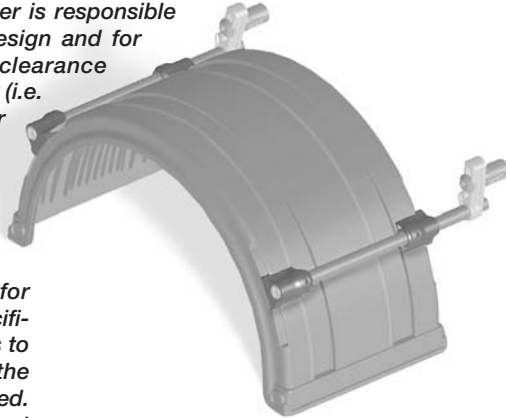

- 1. Position fender over tires.** Use a 2x4 block or other suitable spacer to achieve desired clearance around tires. (S.A.E. Recommendation is 3" minimum)

*Note: If you have an air suspension make sure there is tire clearance when the suspension is deflated.*

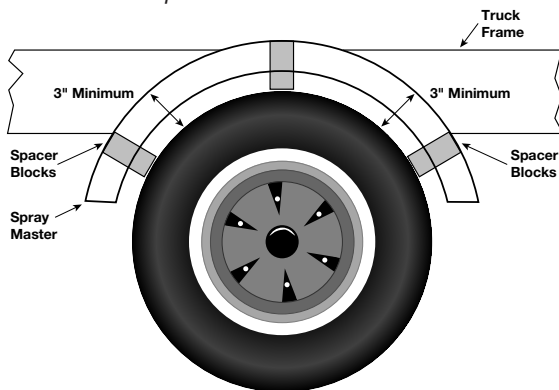

- 2. Assemble the Slidetrax clamps** by inserting the threaded T-nuts into the clamps from the inside and pushing them into place.



- 3. Insert a Master Mount tube (or the Master Multi-Mount)** through a Slidetrax clamp to use as a guide. On the frame side of the fender, position the clamp (with tube) on the Slidetrax. Move the clamp on the Slidetrax as necessary to select an existing hole or mark a space on the frame to drill a new hole.

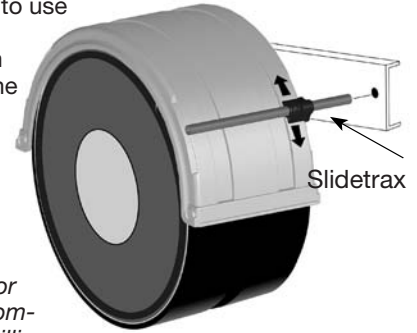

*Note: Be sure to follow truck or trailer manufactureres recommended procedures for drilling any required holes in the frame.*

- 4. Once the position of the master mount is chosen,** slide the other Slidetrax clamp onto the tube, making sure that they are square to the truck frame, then mark the positions of the clamps on the Spray Master fender.

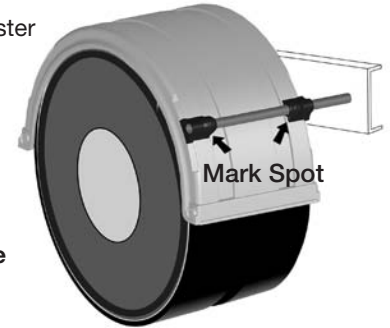

- 5. Repeat step 3 and 4 for the other mount.**

- 6. Remove the fender from over the tire and place the Slidetrax clamps on the Spray Master fender at the marked positions.** Engage the Slidetrax teeth and firmly push clamps onto the fender until they snap into place. Once in place, rap with a soft hammer to seat the clamp into the Slidetrax.



*Note: If clamp removal or reposition is necessary, an outward rap with a soft hammer will disengage it.*

- 7. Mount the Master Mounts to the truck frame** according to the instructions provided with the mounts.

*Note: It may be easier to leave the bolts loose enough to allow some movement until the final positioning of the fender.*

- 8. Slide the Spray Master fender with attached Slidetrax clamps on to the Master Mounts already attached to the frame.**

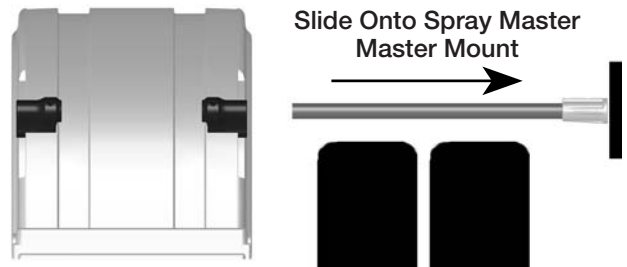

- 9. Position the fender over the tires and secure in place by tightening all bolts to the proper torque and installing the set screws in the Slidetrax clamps and tightening to maximum torque of 144 in. lbs. or 12 ft. lbs.**

**Please Note:**

*Flap weights are not recommended and may void the warranty.*

*Painting Spray Master fenders IS NOT recommended and may void the warranty. If painting is desired, a Flex Agent MUST be added to the paint!*

